

THREAD

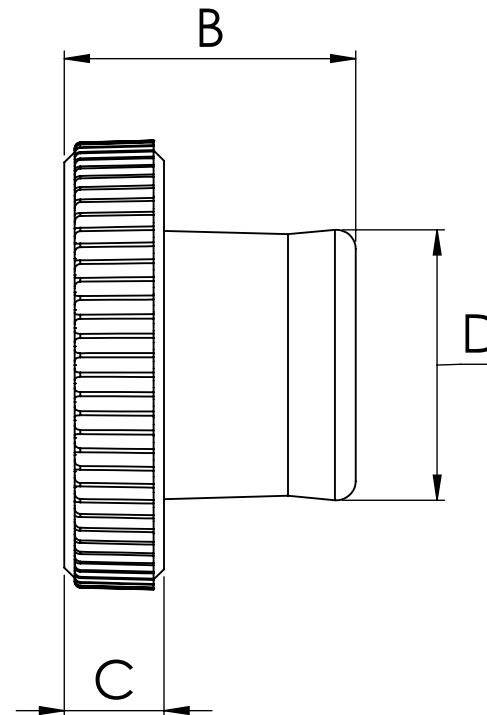
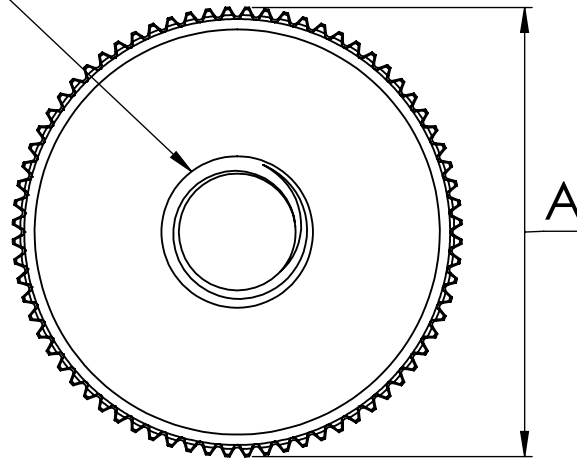

Dimensions (In Inches)

THREAD	A	B	C	D
1/4 - 20	3/4"	1/2"	11/64"	9/20"

Shear-Loc Products
 23191 Peralta Dr.
 Laguna Hills, CA 92653
 PHONE: 949-768-8985
 FAX: 949-768-8705
 Email: sales@shear-loc.com
<https://www.shear-loc.com>
 ©2020 Shear-Loc Products®

	NAME	DATE
DRAWN	A.Kovacs	
CHECKED		
COMMENTS:		
PROPRIETARY AND CONFIDENTIAL		
<small>THE INFORMATION CONTAINED IN THIS DRAWING IS THE SOLE PROPERTY OF SHEAR-LOC PRODUCTS. ANY REPRODUCTION IN PART OR AS A WHOLE WITHOUT THE WRITTEN PERMISSION OF SHEAR-LOC PRODUCTS IS PROHIBITED.</small>		

shear-loc
 PRODUCTS *Since 1969*

TITLE:
 3/4" Knurled Knob with
 Machine Tapped Hole

SIZE	DWG. NO.	REV
A	TH03B-MT-2520P	
SCALE: NONE	WEIGHT:	SHEET 1 OF 1

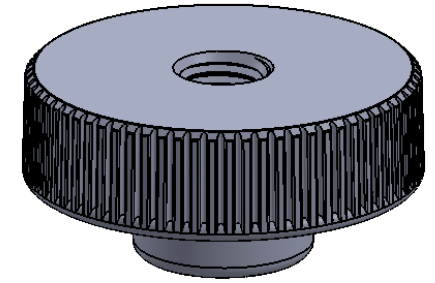

THREAD

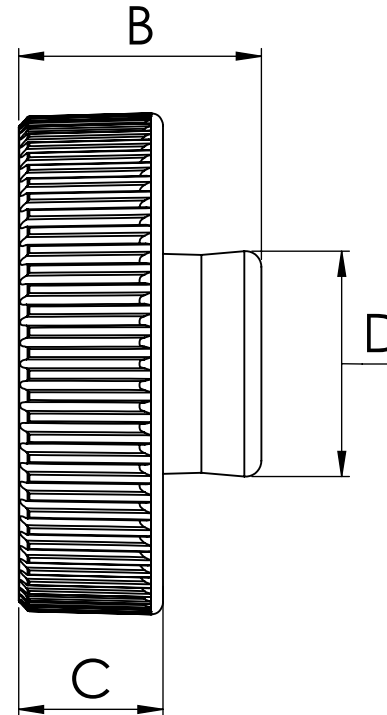
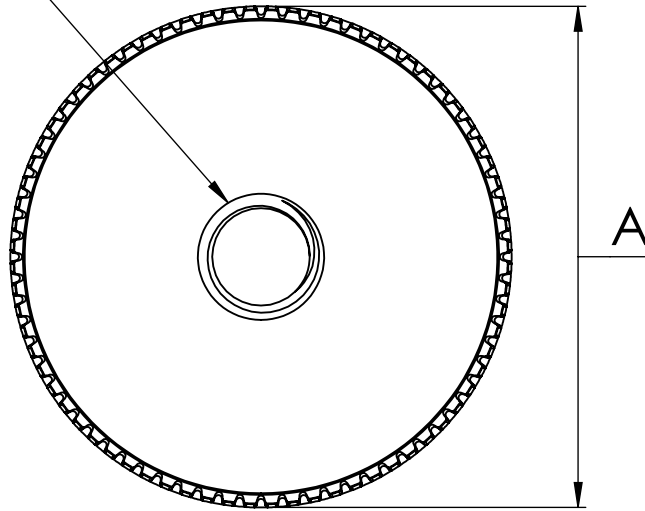

Dimensions (In Inches)

THREAD	A	B	C	D
1/4 - 20	1"	1/2"	19/64"	9/20"

Shear-Loc Products

23191 Peralta Dr.
Laguna Hills, CA 92653

PHONE: 949-768-8985

FAX: 949-768-8705

Email: sales@shear-loc.com

https://www.shear-loc.com

©2020 Shear-Loc Products®

	NAME	DATE
DRAWN	A.Kovacs	
CHECKED		

COMMENTS:

PROPRIETARY AND CONFIDENTIAL
THE INFORMATION CONTAINED IN THIS DRAWING IS THE SOLE PROPERTY OF SHEAR-LOC PRODUCTS. ANY REPRODUCTION IN PART OR AS A WHOLE WITHOUT THE WRITTEN PERMISSION OF SHEAR-LOC PRODUCTS IS PROHIBITED.

shear-loc
PRODUCTS *Since 1969*

TITLE:
1" Knurled Knob with
Machine Tapped Hole

SIZE	DWG. NO.	REV
A	TH04B-MT-2520P	
SCALE: NONE	WEIGHT:	SHEET 1 OF 1

THREAD

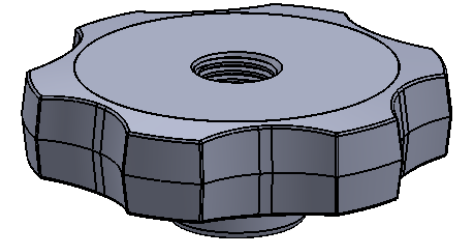
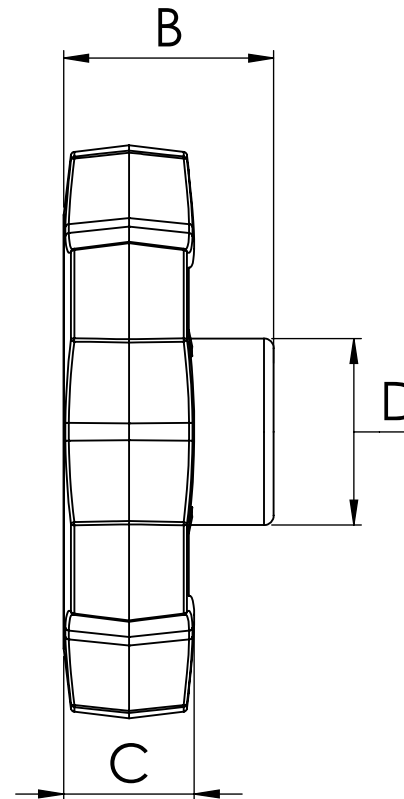
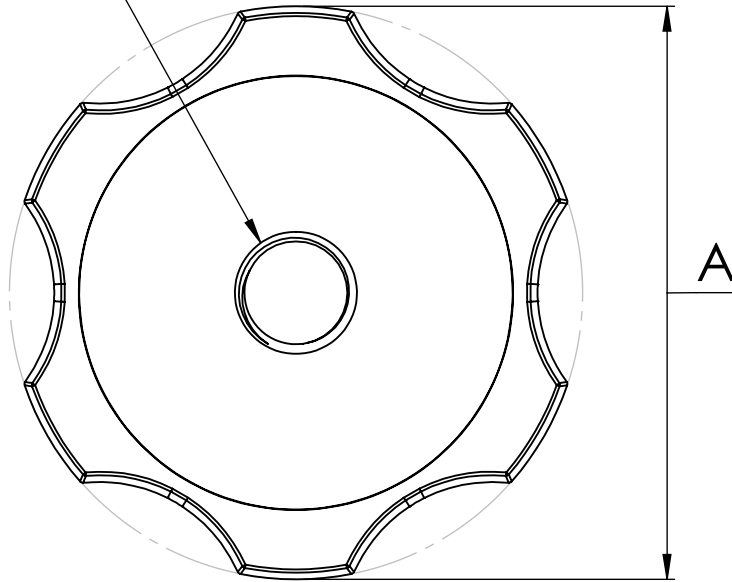

Dimensions (In Inches)

THREAD	A	B	C	D
5/16 - 18	1 1/2"	9/16"	3/8"	31/64"
5/16 - 24	1 1/2"	9/16"	3/8"	31/64"

Shear-Loc Products

23191 Peralta Dr.
Laguna Hills, CA 92653

PHONE: 949-768-8985

FAX: 949-768-8705

Email: sales@shear-loc.com

<https://www.shear-loc.com>

©2020 Shear-Loc Products®

	NAME	DATE
DRAWN	A.Kovacs	
CHECKED		
COMMENTS:		

PROPRIETARY AND CONFIDENTIAL
THE INFORMATION CONTAINED IN THIS DRAWING IS THE SOLE PROPERTY OF SHEAR-LOC PRODUCTS. ANY REPRODUCTION IN PART OR AS A WHOLE WITHOUT THE WRITTEN PERMISSION OF SHEAR-LOC PRODUCTS IS PROHIBITED.

shear-Loc
PRODUCTS *Since 1969*

TITLE:
1 1/2" Rosette Knob with Machine Tapped Hole

SIZE	DWG. NO.	REV
A	TH08B-MT-3118P TH08B-MT-3124P	

SCALE: NONE WEIGHT: SHEET 1 OF 1

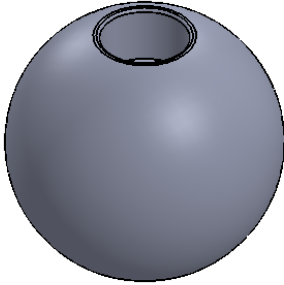

THREAD

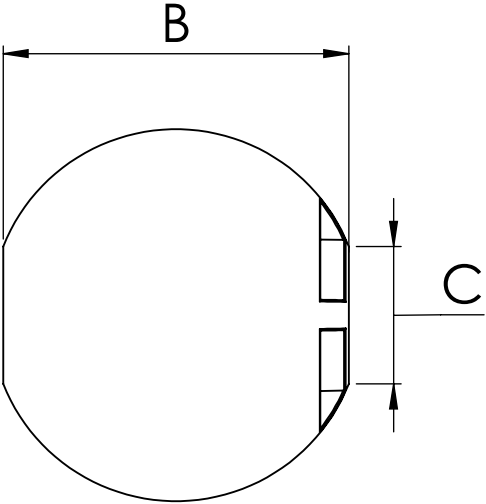
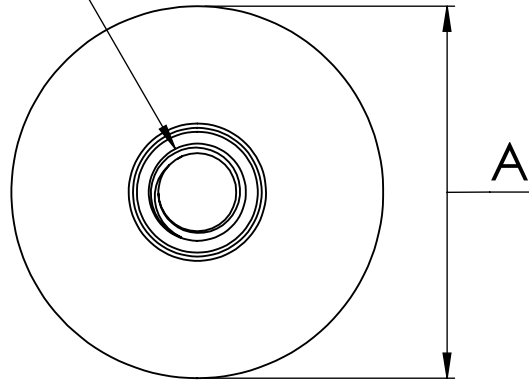

Dimensions (In Inches)

THREAD	A	B	C
1/4 - 20	31/32"	29/32"	13/32"
1/4 - 28	31/32"	29/32"	13/32"

Shear-Loc Products

23191 Peralta Dr.
Laguna Hills, CA 92653

PHONE: 949-768-8985

FAX: 949-768-8705

Email: sales@shear-loc.com

https://www.shear-loc.com

©2020 Shear-Loc Products®

	NAME	DATE
DRAWN	A.Kovacs	
CHECKED		
COMMENTS:		

PROPRIETARY AND CONFIDENTIAL
 THE INFORMATION CONTAINED IN THIS DRAWING IS THE SOLE PROPERTY OF SHEAR-LOC PRODUCTS. ANY REPRODUCTION IN PART OR AS A WHOLE WITHOUT THE WRITTEN PERMISSION OF SHEAR-LOC PRODUCTS IS PROHIBITED.



TITLE:
31/32" Ball Knob with Machine Tapped Hole

SIZE	DWG. NO.	REV
A	TB2-MT Inch	

SCALE: NONE | WEIGHT: | SHEET 1 OF 1